

**MORPAC
INDUSTRIES**

LH144 SALVAGE MASTER

The Salvage Master is a utility machine that has been designed to retrieve overhead or underground cable. The machine works as follows:

The overhead cable is attached to the bull ropes on the 60" bull wheels at the front of the machine, this in turn feeds the used cable onto the "Re-claimer" at the rear of the machine. The bull wheels are directly driven by means of a diesel engine. The re-claimer is hydraulically driven and is speed variable using the pressure control mounted on the control console (this is necessary due to the varying diameter of the re-claimer spool).

When the re-claimer is filled, the pull is halted, and the re-claimer is collapsed so the outboard side forms a cone and the core diameter is reduced thus allowing the reclaimed material to be easily removed. No need to manually split a breakaway spool and wrestle the conductor off.

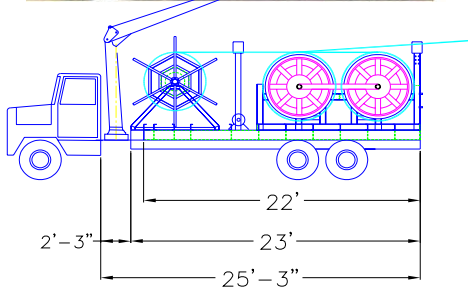

Standard features:

- Designed for single machine conductor removal and salvage operation
- Overhead or underground compatible
- Hydraulically collapsible salvage reel for easy conductor removal (no manual reel splitting)
- Bull Wheel: Max pull 35,000 lb in the present configuration, as a puller tensioner
- Re-claimer Pull Rating: Mid-drum 1,000 lb @ 300 fpm
- Catch Off Winch Capacity: 30,000 lb
- John Deer Power Plant: 250 hp @ 2400 rpm

MORPAC INDUSTRIES, INC.

117 Frontage Road North, Suite A
Pacific, WA 98047-1052

Website: <http://www.morpac.com/>
Email: actuators@morpac.com

Phone:(253) 735-8922
Fax: (253) 735-8933

July 2007

LH144 SALVAGE MASTER



- **Drum capacity:**
 1. 9,500 ft of 477 kcmil ACSR
 2. 6,000 ft of 795 kcmil ACSR
 3. 2,700 ft of 1780 kcmil ACSR
- **Reel Drive:** Hydrostatically driven, variable displacement
- **Fairlead:** Hydraulic operator controlled
- **Optional Features:**
Truck Crane 10,000 lb Capacity. This crane can be controlled from the main console.

Advantages of the LH144:

Safe, rapid, inexpensive and convenient removal of conductors. Utilizes smooth and precise hydraulic power and the positive action of direct drive on the bull wheels.

Eliminates the need to later remove the conductor from a conventional reel. The conductor is assembled in convenient sized rolls to be transported for scrapping. The conductor comes directly off the SALVAGE MASTER, banded or tied in coils for the optimum size and weight to obtain the maximum rate for scrapped material.

The recommended crew size to operate this machine is one operator and one assistant.

This machine is available for rent or sale.

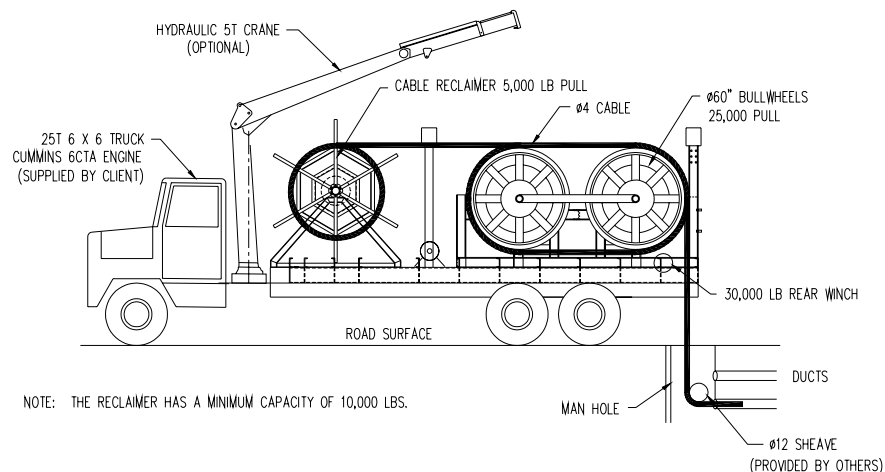

MORPAC INDUSTRIES, INC.

117 Frontage Road North, Suite A
Pacific, WA 98047-1052

Website: <http://www.morpac.com/>
Email: actuators@morpac.com

Phone:(253) 735-8922
Fax: (253) 735-8933